



FLIGHT LINES

The Monthly Newsmagazine of The Spirits of St. Louis R/C Flying Club, Inc.

Happy New Year

PREZ SEZ

By Cecil Whitrock

Well, on New Year's Eve I had been watching the weather twice a day for the past ten days. Wouldn't you know it, the worst weather we have had in the past 30 days was predicted, just in time for our annual January 1, 2008, Fly-In. "HAPPY NEW YEAR".

The start of the Fun-Fly is a balmy 18 degrees Farenheit and the wind is 33 MPH, with gusts to 40 MPH. Just a great day for flying radio-controlled airplanes. Approximately 40 people showed up at the flying field for our annual event. I want to say a special thank you to John Matticken, Don Whitrock, Don Fitch, Carolyn Schlueter, Mark Livesay, Pat Keeby and Greg Boehror for all their help and thank you to all who showed up.

As we start this New Year, I would like for everyone to think of a new flying activity that we can implement, or ways to improve some of the old ones, in order to draw more participation in our events. If you do, bring them to our next club meeting. In closing, I want to wish each of you a very happy and prosperous New Year.

MEETING MINUTES: December 12, 2007

By Walt Wilson

The meeting was called to order at 7:02 P.M. Thirty-four members, applicants, and guests were present.

Members and Applicants:

The following new members and applicants were at the meeting for the first time.

Name	Phone Number
James Olvitt	314-704-0044
Ron Hesskamp	314-781-0711
Gary Mayfield	636-685-0300
Marlin Williams	314-781-0711
Jim Moeller	314-831-3753

They were unanimously accepted and welcomed by the members present.

Secretary's Report: *Walt Wilson*; Minutes were accepted as published in last month's Flight Lines.

Treasurer's Report: *Les Richman*; The Treasurer's Report

was accepted as presented. It was voted to make a donation of \$60.00 to the Make-A-Wish Foundation of Missouri. This was profit from the March Show-N-Tell. It was also noted that we donated \$160.00 worth of food, left over at the Swap Meet, to the Boy Scouts of America. This makes a total of \$220.00 donated to charity this year.

Field Report: *Frank Nolle* started his report by noting that the field was still there. Storage boxes for training equipment are in work and should be completed as soon as the weather improves. A sign is being made to ban hunting or discharge of firearms on club property. The flag needs replacement. It was voted to do so although that's just part of field maintenance. John Ostmann says they have removed all the trees they plan to do. There are still many smaller trees in the flight path to the runway that need to be removed in accordance with our lease agreement. Volunteers are needed to complete the job. Curt Milster started the job a year or so ago, then the property owners took over. Maybe Curt will complete the job? Electric line markers have been received and turned over to AmrenUE people for installation. They will do so when present power outages in other areas are resolved.

Safety Report: No new issues were addressed.

Training Report: The program goes on, but a Chief Instructor is still needed.

Membership Report: Forty members have signed up for 2008. Another ten have paid, but haven't submitted their 2008 AMA cards. A lot of regular renewals are delayed due to slow-coming AMA cards. All 2007 memberships expire on December 31. There is a grace period until March 1. After that, all applicants will be considered new and the \$25.00 initiation fee will be required. **It is imperative that your application be accompanied with a copy of your 2008 AMA card!**

Activities Report:

A Schedule of events is being formulated by the President and should be forthcoming by next month.

(Continued on the next page)

FLIGHT LINES

(Continued from the previous page)

Racing Rules Meeting: Paul Geders held a meeting, on December 1, for all interested racers to express their opinions concerning the racing rules and conduct of events. There were eight people present and seven more expressed their views by e-mail. The major concern was that the CD's stick to established rules and procedures, with no deviations to meet peculiar circumstances. Four-Star 40 planes will undergo a technical inspection to assure conformance to the



Bob Fiely discussed his Midwest Aerostar 20, built from a kit. It's powered by an O.S. .25 FX. Bob, who likes to build, lamented the fact that so few BIY kits are available for engines in this size range.



Bill Lindewirth discussed his Nitro Models Bobcat ARF pusher. It has fixed landing gear and an O.S. .61 FX for power. Bill says the hardware and instructions are "junk" and should be discarded. He also had several problems with the layout of servos and other components. The plane is nicely finished and looks good.



Paul Geders brought his Seagull Yak 54 ARF. It has a YS 1.20 pumper four-stroke up front and will hover at 1/3 power. He used all supplied hardware and a Futaba 2.4 GHz radio with digital servos. He says it's well-built and a great value for the money.



Greg Bohrer gave a presentation on Cox Warbirds with the emphasis on batteries. The P-47 Thunderbolt he's holding has been re-painted and modified to use ailerons, rather than rudder. It's powered by a brushless motor with a LiPo battery. Races this year are planned for both stock and modified classes of Cox Warbirds.

rules. Paul has made a template for most measurements. Volunteers are needed to conduct the inspections. Steps by the CD to speed up conduct of the races were discussed. Electric-powered planes are welcome in Warbirds. See a complete report on the meeting, starting on page 3. Don Ware, who was the primary designer of Four-Star 40 racing, and occasionally competes with us, says he hopes to

(Continued on the next page)

FLIGHT LINES

(Continued from the previous page)

come race here next year. He wants to try a twin-engined racer in Warbirds.

New Year's Day Fly-In: Volunteers are needed to bring firewood, chili, and snacks. Contact Cecil at 636-922-0553 or e-mail at cwhitrock@hotmail.com to let him know what you're bringing. Entry is free, there will be free food, hot chocolate and coffee, and this is the place to be on New Years Day! It's a tradition!

OLD BUSINESS: None presented that was not addressed in above reports.

NEW BUSINESS: None presented that was not addressed in above reports.

Meeting Activities: Four members brought planes to show and two others brought a plane and other materials to sell. See the pictures for details.

Meeting was adjourned at 8:53 P.M.

Four-Star 40 Rules Meeting

By Paul Geders

We had a meeting Saturday morning December 1 at 10:00 A.M. to discuss changes to the Four-Star 40 racing rules. See the pictures of attendees freezing. In attendance were: Cecil Whitrock, Pat Keebey, Ron Hesskamp, Bob Gizzie, Babe Raab, Jim Marshall, Marlin Williams, Paul Geders, and two other gentlemen, not affiliated with racing, whose names I did not get.

Paul Geders started by providing a little background on



Eight interested, active and potential racers attended the racers' meeting on December 1, in spite of the cold weather. Seven others stayed home and expressed their views by e-mail.



Paul Geders, one of the most enthusiastic, experienced, and proficient pylon racers and Contest Directors in the Spirits, and a frequent winner, offered to tear down his engine in the presence of all concerned and compare it with a new stock Super Tigre GS 40.

himself. He carries both AMA Leader-Administrator, and Contest Director Cards (an AMA member since 1957). Was the Contest Director of the Q-40 pylon racing at the 1996 and 1997 AMA NATS. He has been racing since the 60's, and has run many pylon racing events. With that said, he handed out current copies of the Four-Star 40 rules dated October 13, 2007, off the club web-site, and the two proposals that were suggested. Paul asked if anyone had any suggested changes to the existing rules. Several discussions ensued. Paul stated that everyone wanted to "stick to the rules", so he showed a template that will be used to check the wing thickness, main wheel diameter and width, tail wheel diameter, prop diameter, fuselage width and vertical fin and stabilizer thickness and radii. Aircraft will also be weighed. If any aircraft does not meet the rules it will not be allowed to race. All CD's will follow the rules to the letter. This was agreed to by everyone present at the meeting. Further discussion regarding the engine occurred. Paul explained that Don Ware, the father of Four-Star 40 racing, kept meticulous records of engine RPM's for several years. Some racers just ran away from the rest of the field with hopped up engines/carburetors that turned about 700 RPM more than anyone else, but they wouldn't idle. Don instituted a rule limiting engines to 15,000 maximum RPM and awarding an extra 1 point for landing with the engine running, which knocked out the hopped-up engines immediately. We also discussed using higher nitro fuels. It just doesn't improve performance in a GS-40 ringed engine. Ron Hesskamp stated they tried all combinations of nitro, to no benefit (i.e. higher RPM's or more power), and 15% still was, and is, the right fuel that will only turn around 16,000 RPM when unloaded in the air. Yes, they had onboard tachometers!

(Continued on the next page)

FLIGHT LINES

(Continued from the previous page)

You need a properly decompressed ABC engine, designed to run on high nitro, which means you need a tuned pipe and pipe timing to get more out of the engine. The point was that higher nitro content does nothing for you in a cheap, non-piped-timed ringed Super Tiger GS-40 engine to get maximum performance. Paul discouraged the club providing the fuel, because of the cost. If you have the stock 10 ounce tank in the plane and run four-plane heats, that's 40 ounces per heat. In three heats you would burn approximately a gallon, times four or five rounds. That is four or five gallons of fuel. Some will complain that they only run synthetic (like Cool Power), and others will want castor based fuel only (like Omega). It was also suggested that, if we went to club furnished fuel, the entrants could pay what amounts to a surcharge to buy the fuel. Five times \$15 = \$75...probably would not be well received.

Relative to the airframe, Paul explained that there were people that would simply "mess with other people's minds". They would do things like lowering the canopy, using 3/16" balsa for vertical fin/rudder, and stabilizer/elevator with sharpened leading edges, radiusing/sharpening the aluminum landing gear, using thin racing wheels, tailskids instead of tailwheels, making the wings thinner, and one individual cut off the outer bay of each wing, flying under weight (before there was a minimum weight rule) etc, etc. All of these were handled very well by Don by instituting the rules we have today. Don never had to use the templates that I can recall (don't even know if he ever really made any). It was more of a deterrent to those that wanted to fiddle with the rules.

The purpose of the meeting swung to the real reason, increasing participation in our racing programs. One such proposal suggested a Novice only class that would not pay an entry fee and would race in a separate heat along with the other racing heats and the winner would receive only a 1st place certificate. It was decided that if at least 2 beginners/novices (self-declared) were to enter that they may run in a separate heat, OR, have to be included in the regular heat matrix and if so they would get a 2 lap head start. This would be based on the CD's discretion relative to things like number of beginners/novices entered, frequency control and any other combination of problems associated with setting up a matrix. If a beginner/novice wins a heat with a 2 lap head start, they automatically get a 1 lap head start in the very next heat. If they win again they get no more handicap laps.

Another great idea, presented by Jim Marshall, was to have a mentoring program. On several Saturdays, the more experienced racers would spend the day teaching anyone interested the finer points of setting up, adjusting, and maintaining an engine, and flying with someone talking them through the course and calling the turns for them. This was well received and will be instituted. Paul volunteered to tear-down his engine and have it "miked" and timed with any other New-In-Box (NIB) engine as part of the mentoring program to show others what a stock engine really is. Discussion on an engine claiming rule was soundly defeated by those present after hearing how the rules evolved to eliminate cheating. Also, there were 7 separate e-mails, by those not present, that were all against an engine claiming rule.

After all was said and done, it was agreed that our rules are "tried and true" and should not be changed. All must be in compliance with the rules, as agreed upon by 7 other racers who could not attend, but submitted e-mails expressing their opinions.

Thanks to all who wrote e-mails, and to those who endured the cold. A very special thanks to Cecil who brought firewood, Pat Keebey for the hot coffee, Bob Gizzie brought some Jalapeno infested chili, and to Carolyn Schlueter and Don Fitch who brought corn bread and a scrumptious pineapple up-side down cake. Ummm good!

Make-A-Wish Donation

Thank you for your generous donation of \$60.00 to the Make-A-Wish Foundation®. Your contribution to Stories of Light 2007, the Foundation's Winter Campaign - ensures that children from our community experience the fantasy of their wishes coming true. Gareth's wish came true when he

and his family experienced a VIP tour of Sea World in Orlando, Florida. Gareth's mother said that the tour was great because the entire family enjoyed the experience and their awesome tour guide was a perfect match. Granting Gareth's wish has made him so happy that he now tells everyone he meets about how he fed Shamu, made Shamu do a jump, and even got to pet Shamu at Sea World. In his mother's words,

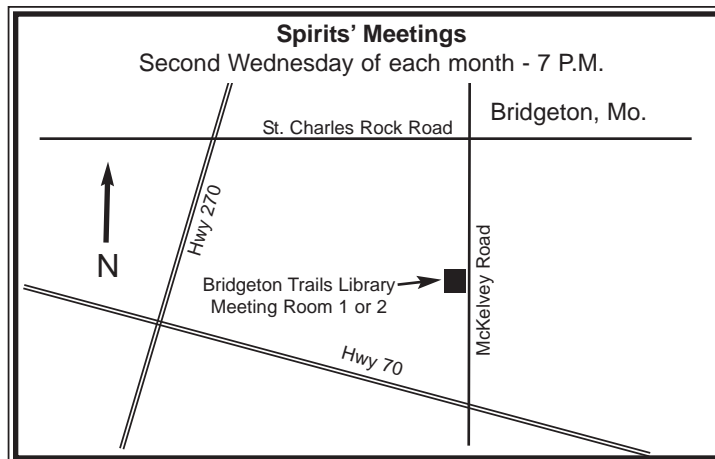

"There is not a thank you card large enough."

On behalf of the more than 3,400 area children we have served, thank you for helping us to *share the power of a wish*.

Best Wishes,

Laura Boone, Development Supervisor

FLIGHT LINES

New Year's Day 2008 Fly-In



The thermometer in the pavilion only tells half the story. The rest of the story was the 30 mph wind, with gusts to 40, that kept the day even more miserable.



Food was in abundance. Mark Livesay (left) kept trying to get the chili hotter!



One of the most popular places at the field was in front of the heater. Three sides of the pavilion were closed in with plastic sheeting.



WALT WILSON PHOTOS

With the exception of one flight, the most action at the field came from Austin Whitrock and his R/C car!



Bob Fiely and Pat Keebey discuss how hot it gets at the field in the summertime!



Jeff Bohrer shows off the electric Mig 25 he designed and his brother, Greg, built and was going to fly.

FLIGHT LINES

New Year's Day 2008 Fly-In



Hey, look at those donuts, and chili, and cornbread, and....



Carolyn Schlueter braves the cold to bring more food, in case the chili runs out!



Cecil Whitrock and Les Richman ask "Can you still feel your feet?" Jim Rawlings peeks around Les.



Don Fitch remembers how warm it was at home.



Austin Whitrock keeps the crowd entertained since it was too windy to fly.



Paul Geders, Les Richman, and Harold Mantz ask "are we having fun yet?"

PHOTOS BY WALT WILSON AND CAROLYN SCHLUETER

FLIGHT LINES

Playing With Dolls

By Don Fitch

Monday, December 17, I went to the field to see what was going on, good idea. Upon arriving I found Jeff Muhs, Bob Gizzie and Cecil Whitrock (the three “you know whats”) a J3 Cub model with an R/C parachutist strapped beneath it. The runway was partially covered with snow but, with ace test pilot Gizzie in the front seat, a take off was attempted. Just before liftoff the left wheel of the tail dragger hit a shallow patch of snow. OOPS, ground loop. As the plane whipped around the R/C parachutist was ejected and, if he had more altitude, he might have survived

Back to the bench, repack, refuel, reattach, restart, and re-launch. This time it was a beautiful take off and climb to altitude (a lot of it). Then, throw the parachutist overboard. The parachutist panics, but the chute opens, and begins a long, slow trip to the middle of a mud field. Everyone was elated by success on the first drop. More flights ensued, more drops, more success. You should have been there, it was a lot more fun than it sounds like.

The Last Word

By Walt Wilson

Here's another idea for working on your planes, either kit built or ARF. It's frequently a problem to install blind nuts on the back of a firewall. This technique is easy and can be done with pieces of hardware found laying around most workshops. Thread a 3/4" (depending upon the thickness of the firewall) screw all the way through a blind nut from the back side. Place a piece of fuel hose over the head of the screw and onto a length of appropriately-sized brass or aluminum tubing. Insert the assembly into the hole in the firewall from the back. Thread a hex nut onto the screw protruding from the front of the firewall. Tighten the hex nut until the blind nut is seated in the firewall. Remove the hex nut and screw from the blind nut. If possible, dab a bit of epoxy around the back edges of the blind nut to help hold it in place. It's now ready for installation of the motor mount.

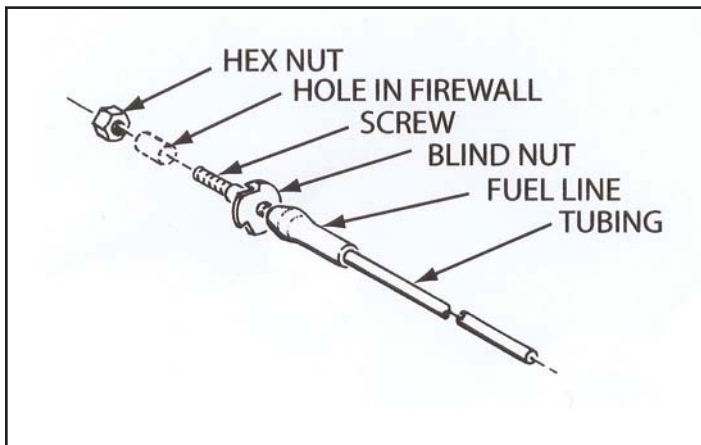

Cecil Whitrock, Bob Gizzie, and Jeff Muhs rig the parachutist for his first drop.



The intrepid parachutist makes his first successful drop! The landing was in the middle of a muddy field, but what the heck...it was fun!

It's the dead of winter, now, and time to build or refurbish your stable of flying stock. There are some new concepts being addressed this year. The Cox Warbirds are becoming popular and won't break the bank, even if you go hotrod and buy the brushless power train with a good LiPo battery. The “Run Whatcha Brung” races open new possibilities for types of planes seldom seen at the field. Quickee 500 type planes used to be very popular and many of us flew them for sport, as well as racing. They're simple, cheap, easy to build, and are available as ARF's. They fly amazingly well, too. The Bohrer brothers keep coming up with scratch-designed, and built, foam and electric creations that remind me of days gone by, before ARF's.

That's it! Gotta go build!

PHOTOS BY DON FITCH

ILLUSTRATION BY WALT AND SUZI WILSON

FLIGHT LINES

FLIGHT LINES is the Spirits of St. Louis R/C Flying Club newsletter and is published on a monthly basis. Club members may submit personal classified ads for inclusion in the newsletter free of charge. Businesses wishing to advertise in the newsletter should contact the editor or an officer of the club for details.

Newsletter Editor:

Walt Wilson
3000 Persimmon Dr.
St. Charles, MO 63301-0131
Phone: (636) 946-6167
e-mail: rallyo@charter.net

Contributing Photographers:

Don Fitch, Carolyn Schlueter, and Bob Gizzie

Newsletter submissions must be in by the Monday following the club meeting in order to make publishing deadlines. The preferred format for article submission is via e-mail. I have PC computers, use QuarkXpress and Microsoft Word, and I prefer that you send the copy and photographs as e-mail enclosures. If you don't have a program compatible with Word, send the text in the body of the message. Typed or clearly written copy on paper, or a Word or Word for Windows file on a 3.5 inch 1.44MB floppy disk are acceptable if you don't have access to the internet. Photos are welcome and may be in the form of glossy prints, or if scanned or digital, in jpeg, gif or tif format. Photo credits will be given.

General Membership meetings are the second Wednesday of each month at the Bridgeton Trails County Library Branch, 3455 McKelvey Rd. (1/4 mi. south of St. Charles Rock Road) at 7:00 P.M.

Membership information can be obtained from:

John Key
24 Briarwick Trail
St. Peters, MO 63376
Phone : 636-922-2556

Flying Field: Our field is located on Amrein Road, off Greens Bottom Road in St. Charles County. It's open for flying daily from 9:00 A.M. to dusk. Flight Training may be arranged by appointment. See our web site at <http://www.spiritsofstl.com> for a list of instructors and times when they may be available.

CAROLYN SCHLUETER PHOTO



Resourceful members closed in three sides of the pavilion with plastic and plywood for the New Years day Fly-In. It was still too cold!

For Sale:

Sig Kadet Senior ARF NIB for \$125. This plane sells for \$225 at Tower Hobbies.

Whisper 1400 EP Super Combo NIB for \$75. This plane sells for \$119.99 at thundertiger4u.com.

Payment by cash, local pickup only. Call Barry Mizes at: 314-721-1841, or e-mail: at: bmizes@yahoo.com

For Sale: Microsoft Flight Simulator 2004, \$ 30.00. Call Les Richman at 314 434 8080 or e-mail at: citabria77@aol.com.



For Sale: Totally Ready to Fly: Eagle II Trainer. Includes new Super Tigre .40 with Spinner & Prop, four new Futaba S-2003 servos, and Sanyo 700 mAh Battery Pack. Completely setup and ready to fly. Just add receiver and fuel. \$185.00

Call: Bill Lindewirth at 314-839-0282, cell: 314-307-6485, or e-mail at: MrBillSTL@aol.com



SPIRITS OF ST. LOUIS R/C FLYING CLUB, INC. MEMBERSHIP APPLICATION



FOR YEAR _____
(PLEASE FILL IN YEAR ABOVE)

PLEASE PRINT CLEARLY!

Name: _____

Address: _____

City: _____

State: _____ Zip: _____ Phone: _____

AMA No. _____

Your e-mail address: _____

Additional Family Members:

Check appropriate below!

- Full Membership (\$125)
- New Member Initiation Fee (\$25)
- Family Membership (\$150)
- Junior Membership, under 16 (\$25)
- Associate (Non-flying) Membership (\$25)
- Temporary Membership (\$10/Month, Max 4 Months & Lives more than 75 miles from field)

Name: AMA #	Name: AMA #	Name: AMA #

NOTE: ANY MEMBER WHO ALLOWS THEIR MEMBERSHIP TO LAPSE BEYOND MARCH 1 OF ANY YEAR SHALL BE CONSIDERED A NEW MEMBER WHEN RENEWING THEIR MEMBERSHIP. SOURCE: ARTICLE 7 SECTION 1, AND 4, CLUB BYLAWS. DUES ARE PAYABLE NO LATER THAN THE JANUARY CLUB MEETING.

To become a new member or renew your membership, please do the following:

1. Fill in the above information, even if this is a renewal.
2. Photocopy this application with valid AMA license of each flying member in the spaces below.
3. Make out a check payable to SPIRITS OF ST. LOUIS R/C FLYING CLUB, INC. (**NO CASH PLEASE**)
4. Send completed application and check to the membership chairperson: →→→→→

Membership Chairperson

John Key
24 Briarwick Trail
St. Peters, MO 63376
Phone No. 636-922-2556

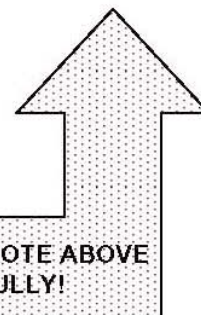

READ NOTE ABOVE
CAREFULLY!

If you apply at a club meeting, be sure to have all three of the above items. Meetings are held on the second Wednesday of each month, 7:00 p.m., at the Bridgeton Trails County Library Branch, 3455 McKelvey Rd.

Note: New Members shall be introduced in person OR, by their sponsor, to the club before joining. This allows new members to join the club, even though their schedule doesn't allow them to attend club meetings. New members who join in August or September will pay \$10.00 each for August and/or September, and will also pay next year's dues and initiation fee at the same time. New members who join on/after October 1st pay only the annual membership amount and the initiation fee, but get the next year and the end of the current year included. Junior members pay no initiation fee and \$2.50 each for August and/or September!

MEMBERSHIP AGREEMENT:

I agree to abide by the SAFETY RULES and CONSTITUTION & BY-LAWS of the SPIRITS OF ST. LOUIS R/C FLYING CLUB, INC.

Signature

Date: _____

Family Member Signature

Date: _____

Membership rejected if not signed and dated, or AMA card NOT VALID FOR YEAR APPLIED FOR!

Spirits Web-site Address is: <http://spiritsofstl.com>

Place AMA card here when
photocopying

Place AMA card here when
photocopying

AMA "Introductory Membership" Program NOT VALID for membership to our club!

FLIGHT LINES



WALT WILSON PHOTO

Jeff Bohrer launches brother Greg's scratch-built electric Mig 25 for the first and only flight at the New Year's Day, 2008 Fly-In. The over 30 MPH winds took it almost straight up! The one-lap flight was completed without any damage to the plane.



FLIGHT LINES

Walt Wilson
3000 Persimmon Drive
St. Charles, MO 63301-0131

www.spiritsofstl.com

**Meeting is on
Wednesday,
January 9,
at 7:00 P.M.**